

INSTRUCTIONS

Taurus (BM) Unit Assembly



Tool Selection			
QTY	Description	QTY	Description
1	Flat head screw driver	1	Air ratchet
1	Drill with 1/4" Bit	1	7/16" deep well socket (for wood base)
1	Drill with 3/16" Bit	1	9/16" deep well socket (for roto-molded base)
1	Rivet Gun	1	Stopper for 3/16" drill bit.
1	Phillips #3 Screw Driver		

Read all instructions carefully before starting assembly. All orientation descriptions are facing the front of completed unit. Call your Synergy World sales representative if you have any questions. 800-352-1986 USA only and Direct #763-519-6526

Ensure all unit components and fasteners are present before starting to assemble unit.

Additional Notes:

- 1) In order to assure proper alignment and structural integrity, the Front, Walls w/corner posts, and Base must be assembled in said sequence. Roof can be joined prior to Base/Wall joint.
- 2) This manual can be used to identify item numbers for ordering replenishment.



2530 Xenium Lane North, Minneapolis, MN 55441
Telephone: 763-553-1900 / Fax: 763-553-1905
800-328-3332/ www.satelliteindustries.com

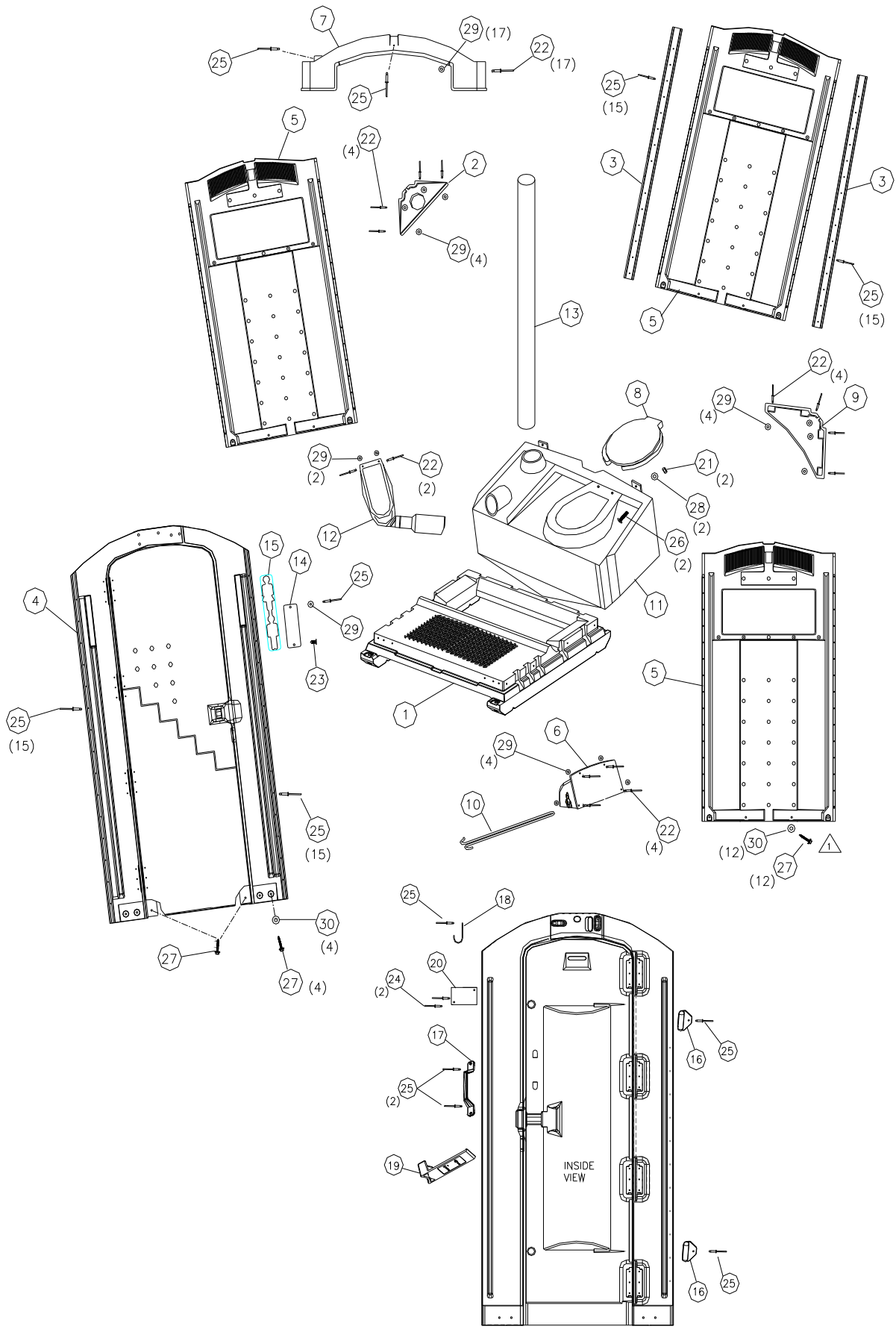

△ HDWE, TAURUS (BM) (#18709)

30	11368	16	WASHER, 5/16 FLAT STNLS
29	11315	32	WASHER, 3/16 RIVET STNLS
28	12382	2	WASHER, 1/4 FLAT STNLS
27	13860	18	SCREW, #14 X 1-1/2 W/WSH GOLD
26	18705	2	SCREW, 1/4-20 X 3/4 TRUSS STNLS
25	18755	68	RIVET, ADVEL SILVER LONG
24	11027	2	RIVET, #66 ALUM
23	16804	1	RIVET, PINE TREE 1/4 X 9/16
22	11054	31	RIVET, #68 AAL POP
21	13128	2	NUT, 1/4-20 NYLOC
20	18710	1	MIRROR, 3 X 5 PLASTIC
19	19592	1	LATCH, SLID ELBOW L/PRO W/ENG
18	10891	1	HOOK, FLAT COAT
17	16807	1	HANDLE, PLASTIC HOVER
16	18707	2	GUIDE, HT DOOR SPRING
15	18808	1	DECAL, SYN GENDER 2 X 11 WHITE
14	18807	1	COVER, TAURUS GENDER

STANDARD TAURUS ROTOMOLDED BASE

13	18754	1	VENT PIPE, SYN 4X64 BLACK
12	18700	1	URINAL, TRS/HT W/TUBE
11	18934	1	TANK, TAURUS DGRY
10	18529	1	SPINDLE, PAPERGRD 3 ROLL METAL
9	18735	1	SHELF, TAURUS MGRY
8	14959	1	SEAT, ELONGATED BLACK
7	18683	1	ROOF, TAURUS
6	18652	1	HOOD, PAPERGUARD 3 ROLL
△ 3	18709	1	HDWE, TAURUS (BM)
5	18821	3	DESIGN, TAURUS PANEL
4	18765	1	DESIGN, TAURUS FRONT ASSY (BM)
3	18764	2	DESIGN, TAURUS CORNER POST
2	18736	1	BRKT SHELF, TAURUS MGRY
1	18615	1	BASE, TRS/HT ROTOMOLD
ITEM #	PART #	QTY	DESCRIPTION

1. Place base on floor and tank in base.



2. Assemble toilet seat to tank.



3. Remove shipping screw from bottom of door and open door to 90 degrees.



4. Retrieve (2) panels and lean them against the door.



5. Rivet right panel to door jamb- fasten top, center and bottom using Rivet Expanding #18755 (30) and repeat on left side. This will hold parts together. (Note: The panels overlap on the front. Also you can finish riveting remaining holes at this time.)



6. Fasten the right wall, back wall and post together. Rivet the top hole with Rivet Expanding #18755 first. Then finish riveting remaining holes with Rivet Expanding #18755 (30). Repeat the same step on the left side. (Note: The rear panel needs to overlap the left side panel and the right side panel needs to overlap the rear panel on the rear of the toilet.)



7. Tip cabana back and lift over tank and base.



8. Fasten the cabana to base.



8 Plastic Roto-Molded Base. Always tighten the front jambs first with dimples in base. Align jambs to be parallel to the door edge from top to bottom. Then fasten panels to base: start at corners and then center holes. Use screw, #14 x 1-1/2" #13860 (18) and washers, 5/16" #11368 (16). Stop tightening when washer is tight, to avoid stripping out hole.

9. Place the roof on the unit so that the vent hole is in the left rear corner. Center the belt strap groove on the roof with the supporting groove on the wall. (See fig. A) Pull down roof corners before drilling. Drill through dimple in tab and panel with a 3/16" drill bit. Fasten with Rivet #68 AAL #11054 (17) and Washer, 3/16" #11315 (17). (See fig. B)(Note: Rivets on outside and washers on the inside.) Repeat this on all (3) sides first. Pull down on roof before drilling. (See fig. C) Repeat this on remaining dimples in the roof. There is (1) dimple, on the inside of each facing for fastening the roof to the front. Drill out center on roof (peak of roof) with a 3/16" drill bit. Just drill through one layer and rivet with expanding Rivet #18755 (1). (See fig. D) When complete, roof corners must slope for drainage.

A



B



C



D



10. Fasten the tank to the back wall. Drill 1/4" hole through each tank tab and back wall. Fasten the tank to the back wall with 1/4-20 x 3/4 Truss STNLS #18705 (2), Nut, 1/4-20 nylon #13128 (2) and Washer, 1/4" flat #12382 (2). Washers and nuts are on the outside of the unit.



11. Fasten coat hook: Drill dimple with 3/16" drill bit. Drill only through first layer. Fasten coat hook #10891 (1) to the door using expanding rivets #18755 (1). (See fig. A)



A



B

12. Fasten Mirror: Drill out the (2) Dimple with 3/16" drill bit. Drilling only through first layer. Fasten with Rivets #66 Alum #11027 (2). (See fig. B) Remove protective film from Mirror.

13. Fasten Door Handle: Drill dimple with 3/16" drill bit. Drilling only through first layer. Fasten the Handle, door #16807 (1) to the door with Expanding Rivets, #18755 (2). (See fig. C)



C



D



14. Drill out the (3) dimples in the recess area for gender indicator with a 1/4" drill bit. Attach gender label sticker in recess area. Poke hole through sticker with a Phillips screwdriver. Fasten gender cover with Rivet, Expanding #18755 (1) Thru hole in Cover, Gender #18807 (1) a Washer, 3/16" #11315 (1) and Rivet into center hole in Gender Indicator Recess Location. The washer under the cover will prevent cover from rubbing on Gender Label. Install plastic pine tree Rivet #16804 in remaining hole. (See fig. D)

15. Install door latch in pocket on the inside of the door. The door latch must fit securely, but must move with some resistance.



16. Place shelf (with vent hole) in left back corner. Drill out the (4) dimples in panel with a 3/16" drill bit and through shelf. Fasten with Rivets, #68 AAL #11054 (8) and Washer, 3/16" #11315 (8). Washers are located on the inside. Repeat with shelf on right back corner.



17. Insert vent tube through roof and shelf into the tank recess. (see Fig. A) Using a 3/16" Drill Bit Drill hole at location shown (see Fig. B). Fasten with Rivet, Silver Long #18755 (1).



A



B

18. Slide the urinal into hole in the tank. Push down on urinal so it is perpendicular with the floor. Align urinal against wall and parallel to wall rib. Drill (2) 3/16" holes through the urinal and side wall. Fasten the urinal with Rivets, #68 AAL #11054 (2) and Washer, 3/16" #11315 (2). Washers are located on the inside of the unit.



19. Insert the hairpin rod (See fig. A) in the toilet paper holder. Drill (4) 3/16" holes through the toilet paper holder and side wall. The right side of the paper holder should be approximately centered in the front grab area. (See fig. A) The top of the paper holder should be flush with the wall rib just below the signage recess. (See fig. B) Fasten the toilet paper holder with Rivets, #68 AAL #11054 (4) and Washer, 3/16" #11315 (4). Washers are located on the inside of the unit.

A



B



20. Position the door spring guides to the recess in the jamb. Using the provided hole in the spring guide, drill (2) 3/16" holes through first layer of the jamb only. Fasten the top and bottom door spring guide by stretching the cable from the door to the jamb with expanding Rivet #18755 (1) on each door spring guide. Check to determine if door catches on roof, by opening door 180° and allowing closing. If roof interferes, remove interfering roof material.

